

CUSTOMER APPROVAL

NAME (PRINTED): _____

NAME (SIGNED): _____

DATE: _____

RETURN FAX TO 815-232-2150

REVISION HISTORY			
REV	DESCRIPTION	DATE	APPROVED
A	CHANGED SYSTEM FROM LEFT TO RIGHT PUT SONIC TOUCH II ON SYSTEM	9/21/2017	JSW
B	MOVED SYSTEM CONTROLS TO RIGHT FRONT	9/21/2017	JSW



THE INFORMATION CONTAINED IN THIS DRAWING IS THE SOLE PROPERTY OF: **ULTRASONIC POWER CORPORATION**
 FREEPORT, IL 61032 USA
 ANY REPRODUCTION IN PART OR WHOLE WITHOUT THE WRITTEN PERMISSION OF ULTRASONIC POWER IS PROHIBITED.

DESCRIPTION
CUSTOM 204 GALLON SYSTEM WITH HMI AND PLC CONTROL

MATERIAL	DWG #			
-	15C698-30			
FINISH	ENGR	DATE	SHEET	REV
-	JSW	09-20-19	1 OF 2	B

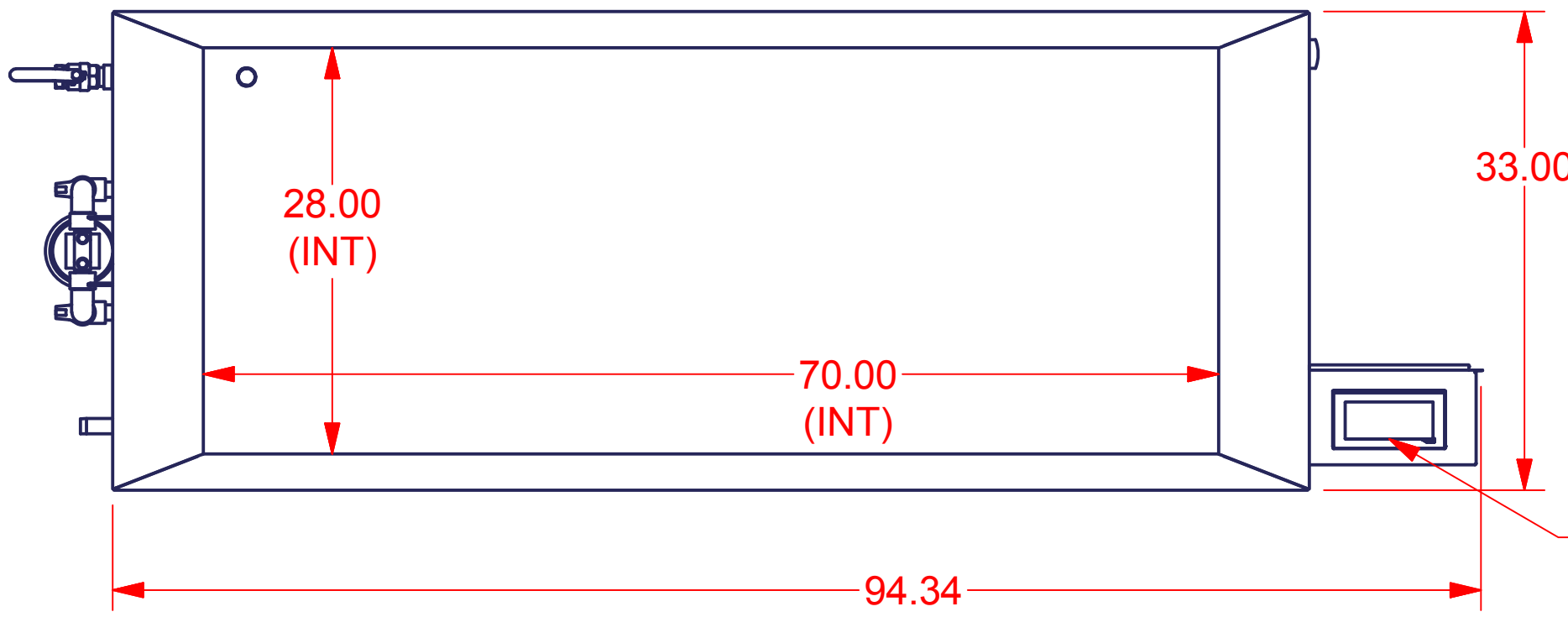
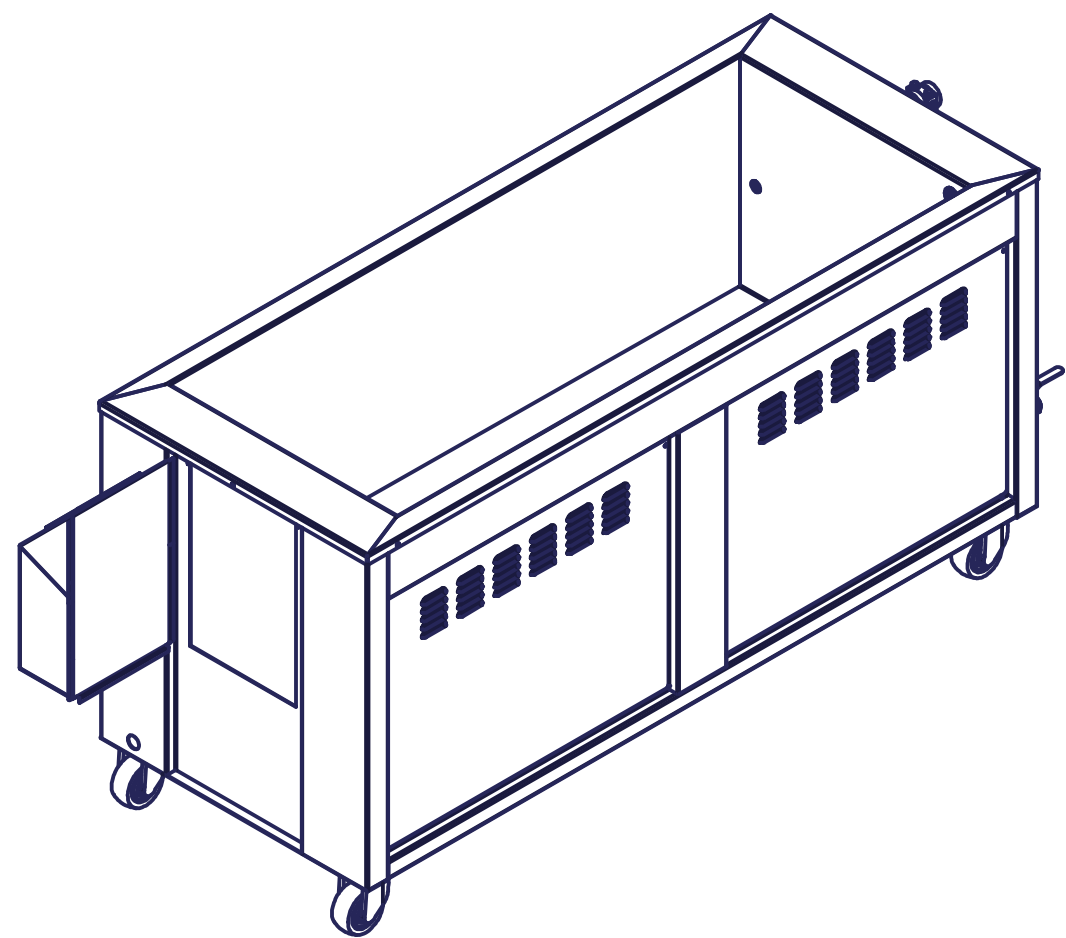

SYSTEM CONTROLS
SONIC TOUCH II

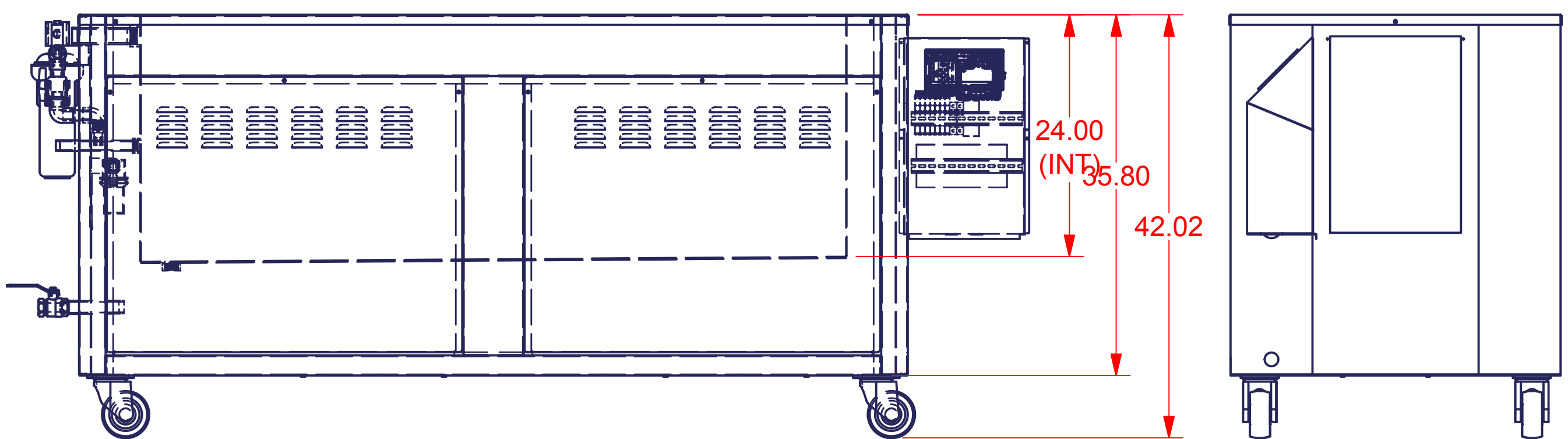

480V/3P
TRANSFORMER NOT SHOWN

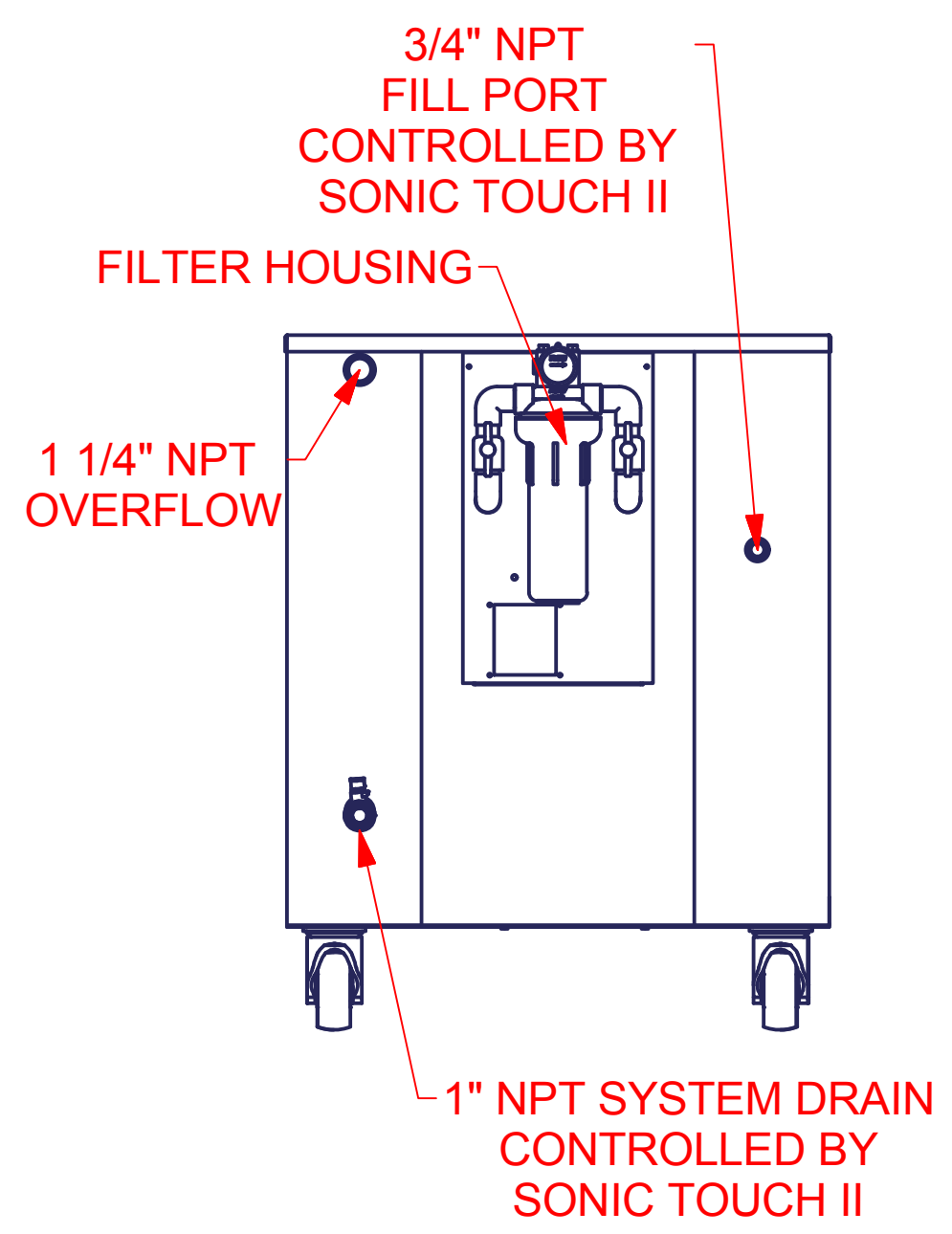

CUSTOMER APPROVAL

NAME (PRINTED): _____
 NAME (SIGNED): _____
 DATE: _____

RETURN FAX TO 815-232-2150

ULTRASONIC POWER CORPORATION

THE INFORMATION CONTAINED IN THIS DRAWING IS THE SOLE PROPERTY OF:
ULTRASONIC POWER CORPORATION
 FREEPORT, IL 61032 USA
 ANY REPRODUCTION IN PART OR WHOLE WITHOUT THE WRITTEN PERMISSION OF ULTRASONIC POWER IS PROHIBITED.

TOLERANCES (UNLESS SPECIFIED)
 FRACTIONS +/- 1/64
 .XX +/- .03
 .XXX +/- .015
 ANGLES +/- 1 DEG
 BREAK ALL SHARP EDGES

DESCRIPTION 204 GALLON TANK WITH OVERFLOW & FILL PORT				
MATERIAL -		DWG # 15C698		
FINISH -	ENGR JSW	DATE 09-20-17	SHEET 2 OF 2	REV B